



**BOMBAS 4" BS**  
**PUMPS 4" BS**



# BOMBA 4" (SERIE BS) - PUMP 4" (BS SERIES)

## CARACTERÍSTICAS - CHARACTERISTICS

### BOMBA (PT)

- Caudal: até 25 m<sup>3</sup>/h a 2850 rpm.
- Altura manométrica: até 521 m a 2850 rpm.
- Saída: 1¼" e 2".
- Ensaio segundo a norma ISO 9906.
- Diâmetro: 98,5 mm.
- Potência: até 7,5 kW.

### CARACTERÍSTICAS

- Bomba do tipo centrífugo multicelular com turbinas flutuantes radiais ou semi-axiais.
- Turbinas e difusores em noryl ou policarbonato com elementos anti-desgaste em aço inoxidável AISI 304.
- Exterior da bomba em aço inoxidável.
- Árvore da bomba em aço inoxidável.
- Instalação vertical ou horizontal.
- Acoplamento: Norma NEMA.

### APLICAÇÕES

- Bombeamento de águas limpas de furos, poços, reservatórios e canais de água.
- Abastecimento de água para aplicações domésticas, irrigação agrícola, sistemas hidroneumáticos, ...

### BOMBA (ESP)

- Caudal: hasta 25 m<sup>3</sup>/h a 2850 rpm.
- Altura manométrica: hasta 521 m a 2850 rpm.
- Salida: 1¼" y 2".
- Ensayos según la norma ISO 9906.
- Diámetro: 98,5 mm.
- Potencia: hasta 7,5 kW

### CARACTERÍSTICAS

- Bomba del tipo centrífugo multicelular con impulsores flotantes radiales o semi-axiales.
- Impulsores y difusores en noryl o policarbonato con elementos anti-desgaste en acero inoxidable AISI 304.
- Exterior de la bomba en acero inoxidable.
- Eje de la bomba en acero inoxidable.
- Instalación vertical o horizontal.
- Acoplamiento: Norma NEMA

### APLICACIONES

- Bombeo de aguas limpas de pozos, depósitos y canales de agua.
- Suministro de agua para aplicaciones domésticas, irrigación agrícola, sistemas hidroneumáticos, ...

### PUMP (ENG)

- Flow: up to 25 m<sup>3</sup>/h at 2850 rpm.
- Manometric head: up to 521 m at 2850 rpm.
- Delivery outlet: 1¼" and 2".
- Tested according standard ISO 9906.
- Diameter: 98,5 mm.
- Power: up to 7,5 kW.

### CHARACTERISTIC

- Multi-stage pumps built in sections with radial or semi-axial floating impellers.
- Impellers and diffusers in noryl or polycarbonate with stainless steel AISI 304 wear rings.
- Pump outside totally in stainless steel.
- Shaft in stainless steel.
- Installation vertical or horizontal.
- Coupling: NEMA standard.

### APPLICATIONS

- Pump clean water from bore holes, reservoirs and lake rivers.
- Domestic water supply, irrigation, spraying watering, sprinkling, pressurization systems, ...

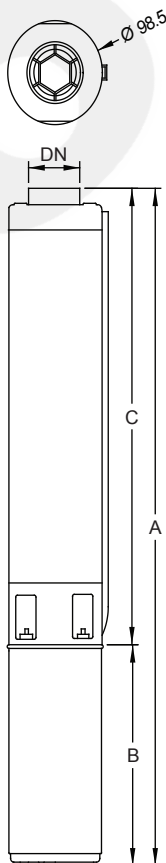

# BOMBA 4" (SERIE BS) - PUMP 4" (BS SERIES)

## PEÇAS - PARTS

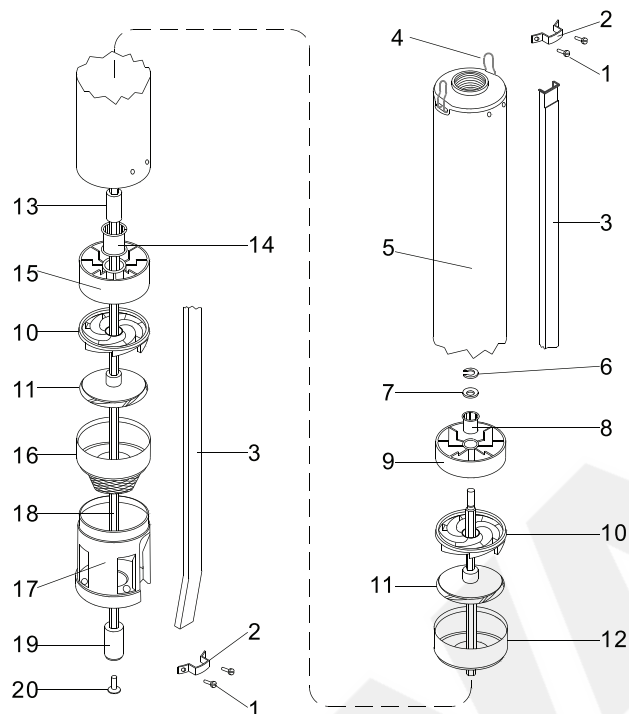

### LEGENDA (PT)

- 1 Parafuso
- 2 Abraçadeira
- 3 Calha protectora do cabo
- 4 Gancho de suporte
- 5 Camisa exterior com válvula
- 6 Freio
- 7 Anilha
- 8 Casquilho da guia superior
- 9 Guia superior
- 10 Difusor
- 11 Turbina
- 12 Copo
- 13 Casquilho
- 14 Casquilho da guia central
- 15 Guia central
- 16 Copo com filtro de aspiração
- 17 Câmara aspirante
- 18 Árvore
- 19 Cardan
- 20 Parafuso

### SUBTÍTULOS (ESP)

- 1 Tornillo
- 2 Abrazadera
- 3 Cubre cable
- 4 Soporte para movimiento
- 5 Camisa exterior con válvula
- 6 Freno
- 7 Arandela
- 8 Casquillo de la guía superior
- 9 Guía superior
- 10 Difusor
- 11 Impulsor
- 12 Aro
- 13 Casquillo
- 14 Casquillo de la guía central
- 15 Guía central
- 16 Aro con filtro de aspiración
- 17 Cuerpo aspirante
- 18 Eje
- 19 Cardan
- 20 Tornillo

### SUBTITLES (ENG)

- 1 Screw
- 2 Brace
- 3 Wire cover
- 4 Support
- 5 Exterior sleeve with valve
- 6 Shaft end pressure
- 7 Washer
- 8 Top bushing
- 9 Top bushing bracket
- 10 Diffuser
- 11 Impeller
- 12 Cover wear box
- 13 Spacer bush
- 14 Bushing
- 15 Bushing bracket
- 16 Cover with filter
- 17 Suction casing
- 18 Shaft
- 19 Cardan
- 20 Coupling attachment

# BOMBA 4" (SERIE BS) - PUMP 4" (BS SERIES)

## CURVAS DE CARACTERÍSTICAS - CHARACTERISTICS CURVES

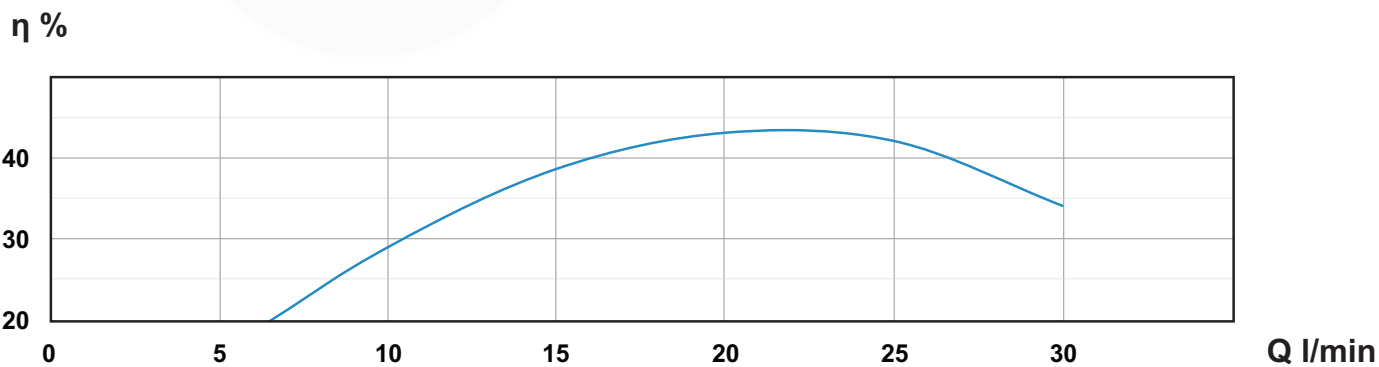
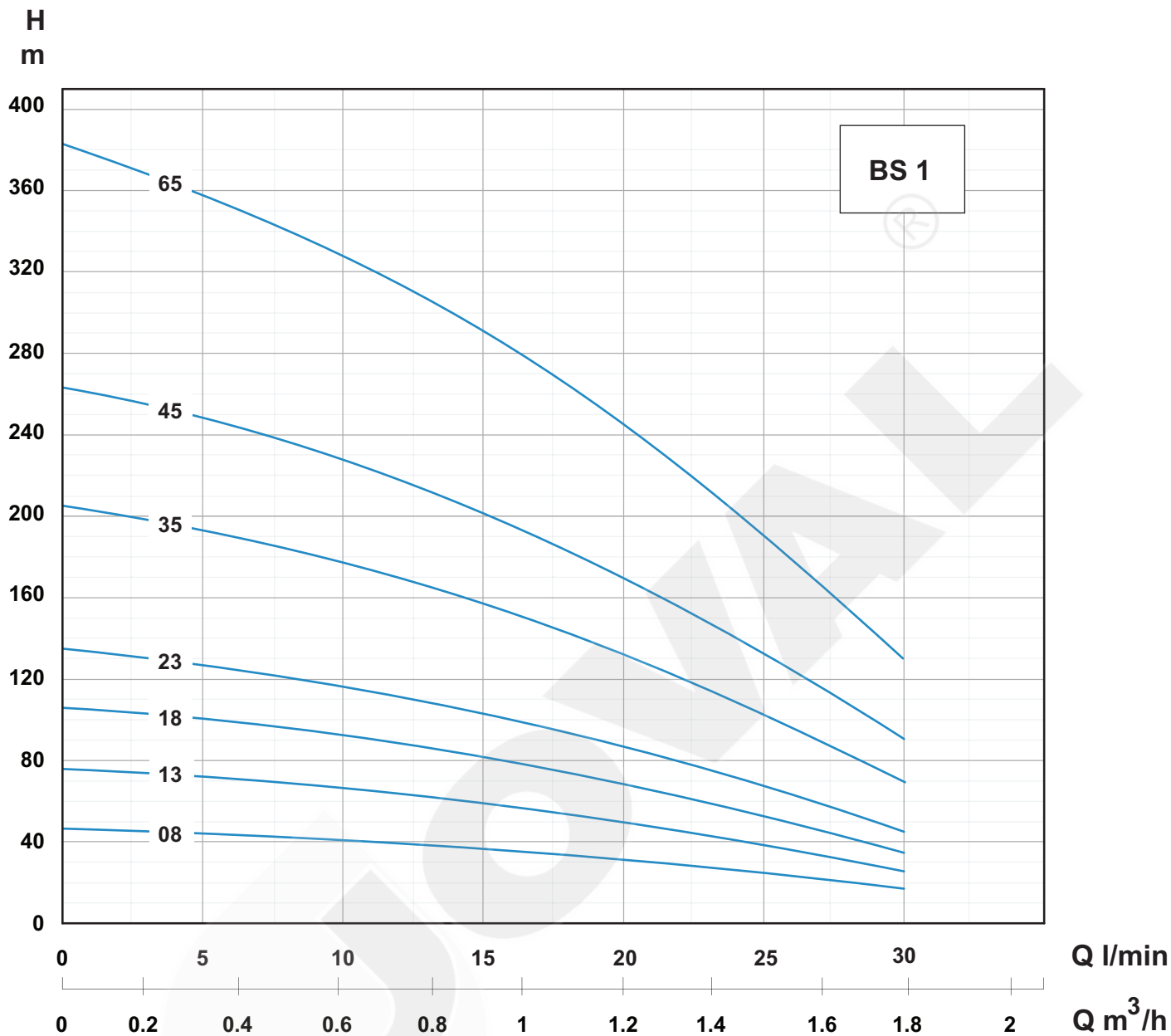

# BOMBA 4" (SERIE BS) - PUMP 4" (BS SERIES)

## CARACTERÍSTICAS - CHARACTERISTICS

Modelo	Motor				Q - Caudal - Flow									
	kW	HP	1~230V	3~400V	m³/h	0	0,6	1,2	1,8	2,4	3	3,6	4,2	4,8
A			A	l/min	0	10	20	30	40	50	60	70	80	
<b>BS1 08</b>	0,25	0,33	2,4		H m	44	40	30	16					
<b>BS1 13</b>	0,37	0,5	3,3	1,1		76	66	49	26					
<b>BS1 18</b>	0,55	0,75	4,3	1,5		106	91	68	36					
<b>BS1 23</b>	0,75	1	5,7	2,0		135	116	86	45					
<b>BS1 35</b>	1,1	1,5	8,4	2,8		205	177	131	69					
<b>BS1 45</b>	1,5	2	10,7	3,9		264	227	169	89					
<b>BS1 65</b>	2,2	3	14,7	5,5		381	328	244	129					

Q - Caudal - Flow      H - Potência nominal do motor - Rated motor power output

Modelo	Peso	Altura	Saída
Model	Weight	Height	Salida
Model	kg	mm	Outlet
<b>BS1 08</b>	3,0	327	1 1/4"
<b>BS1 13</b>	4,0	419	
<b>BS1 18</b>	5,1	553	
<b>BS1 23</b>	6,0	645	
<b>BS1 35</b>	8,5	908	
<b>BS1 45</b>	11,5	1134	
<b>BS1 65</b>	15,5	1586	

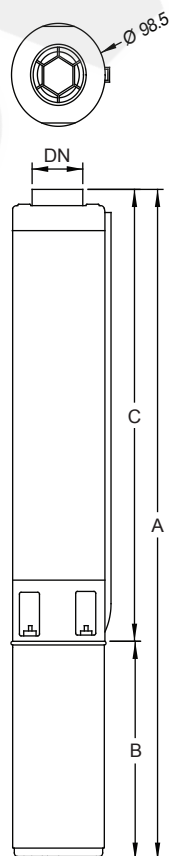

# BOMBA 4" (SERIE BS) - PUMP 4" (BS SERIES)

## CURVAS DE CARACTERÍSTICAS - CHARACTERISTICS CURVES

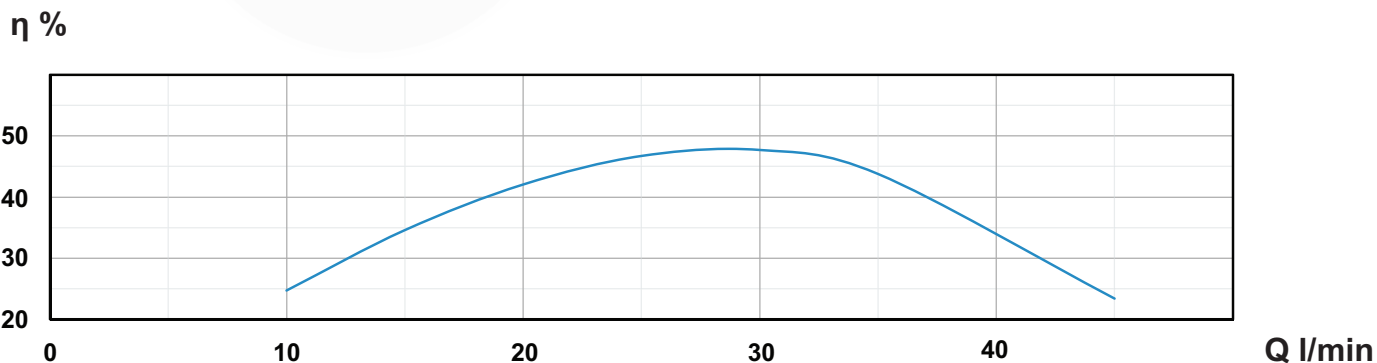
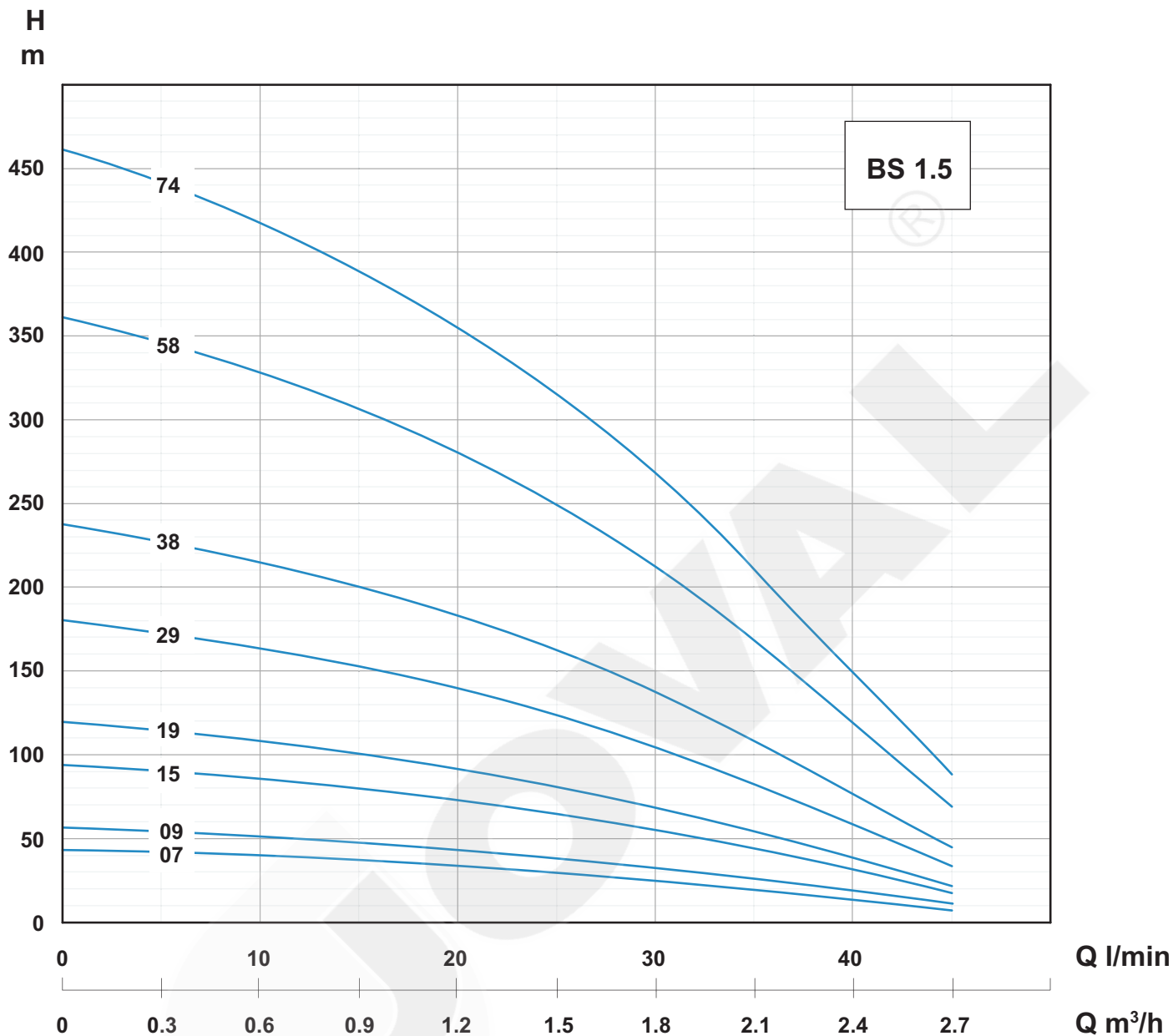

# BOMBA 4" (SERIE BS) - PUMP 4" (BS SERIES)

## CARACTERÍSTICAS - CHARACTERISTICS

Modelo	Motor				Q - Caudal - Flow										
	kW	HP	1~230V	3~400V	m³/h	0	0,6	1,2	1,8	2,4	3	3,6	4,2	4,8	
A			A	l/min	0	10	20	30	40	50	60	70	80		
BS1.5 07	0,25	0,33	2,4		H m	44	40	34	25	15					
BS1.5 09	0,37	0,5	3,3	1,1		56	51	43	33	19					
BS1.5 15	0,55	0,75	4,3	1,5		94	85	72	55	32					
BS1.5 19	0,75	1	5,7	2,0		119	107	91	69	40					
BS1.5 29	1,1	1,5	8,4	2,8		181	164	140	106	61					
BS1.5 38	1,5	2	10,7	3,9		237	215	183	138	79					
BS1.5 58	2,2	3	14,7	5,5		362	328	279	211	120					
BS1.5 74	3	4		7,5		462	418	356	269	151					

Q - Caudal - Flow      H - Potência nominal do motor  
- Flow                      - Rated motor power output

Modelo	Peso	Altura	Saída
Model	Weight	Height	Salida
Model	kg	mm	Outlet
BS1.5 07	2,9	308	1"¼
BS1.5 09	3,1	345	
BS1.5 15	4,1	456	
BS1.5 19	5,4	571	
BS1.5 29	7,3	756	
BS1.5 38	9,3	964	
BS1.5 58	13,4	1375	
BS1.5 74	16,5	1753	

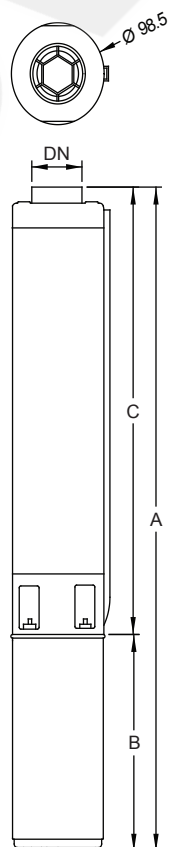

# BOMBA 4" (SERIE BS) - PUMP 4" (BS SERIES)

## CURVAS DE CARACTERÍSTICAS - CHARACTERISTICS CURVES

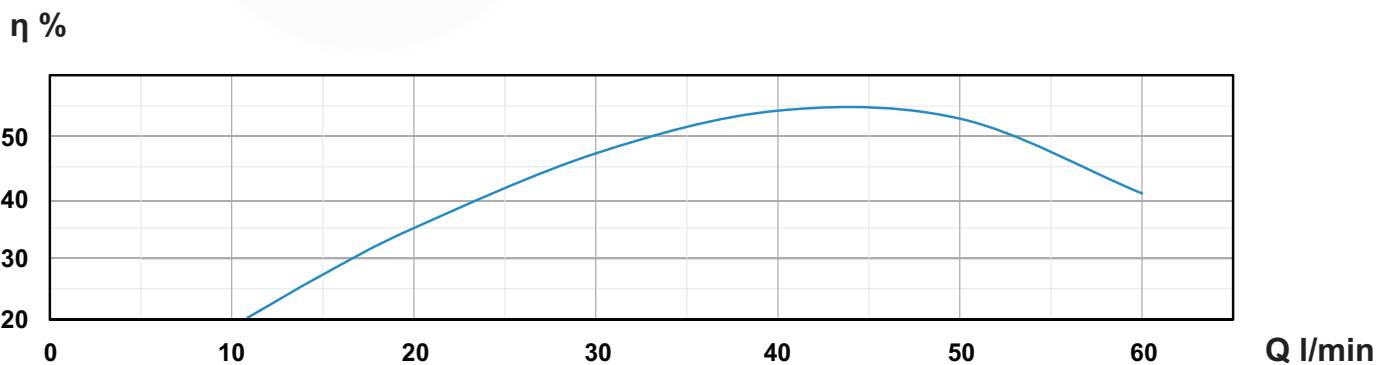
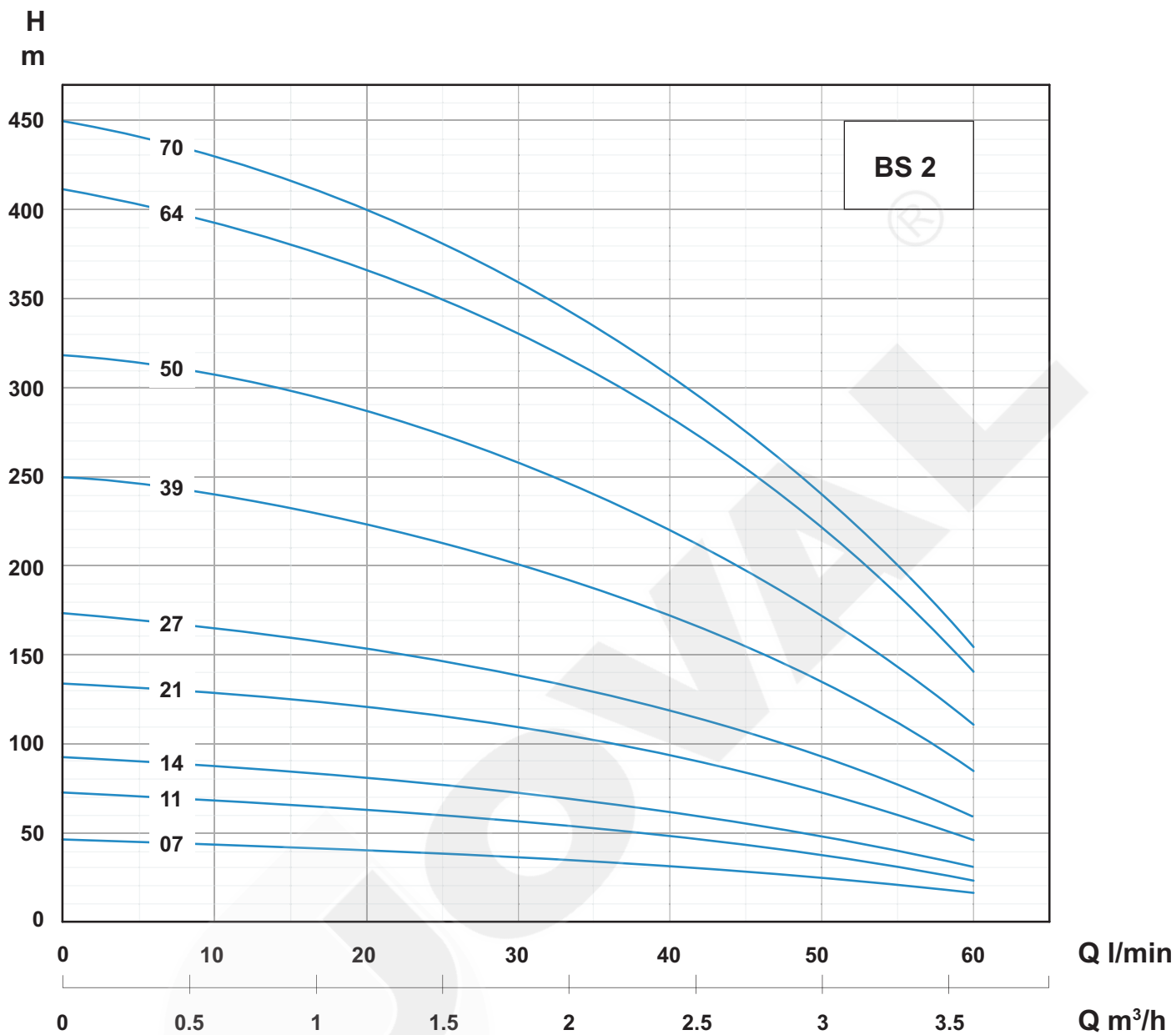

# BOMBA 4" (SERIE BS) - PUMP 4" (BS SERIES)

## CARACTERÍSTICAS - CHARACTERISTICS

Modelo	Motor				Q - Caudal - Flow									
	kW	HP	1~230V	3~400V	m³/h	0	0,6	1,2	1,8	2,4	3	3,6	4,2	4,8
A			A	l/min	0	10	20	30	40	50	60	70	80	
<b>BS2 07</b>	0,37	0,5	3,3	1,1	H m	45	43	40	36	31	24	16		
<b>BS2 11</b>	0,55	0,75	4,3	1,5		71	68	63	57	49	39	25		
<b>BS2 14</b>	0,75	1	5,7	2,0		90	86	80	72	62	49	31		
<b>BS2 21</b>	1,1	1,5	8,4	2,8		135	129	120	108	93	73	47		
<b>BS2 27</b>	1,5	2	10,7	3,9		173	166	154	139	120	93	60		
<b>BS2 39</b>	2,2	3	14,7	5,5		250	240	223	201	173	135	86		
<b>BS2 50</b>	3	4		7,5		321	307	286	257	221	173	111		
<b>BS2 64</b>	3,7	5		9,0		411	393	366	329	283	221	142		
<b>BS2 70</b>	4	5,5		9,9		450	430	400	360	310	242	155		

Q - Caudal  
- Flow

H - Potência nominal do motor  
- Rated motor power output

Modelo	Peso	Altura	Saída
Model	Weight	Height	Salida
Model	kg	mm	Outlet
<b>BS2 07</b>	3,0	308	1"¼
<b>BS2 11</b>	3,7	382	
<b>BS2 14</b>	4,1	438	
<b>BS2 21</b>	5,8	608	
<b>BS2 27</b>	6,8	719	
<b>BS2 39</b>	9,5	982	
<b>BS2 50</b>	12,0	1227	
<b>BS2 64</b>	15,5	1568	
<b>BS2 70</b>	17,0	1679	

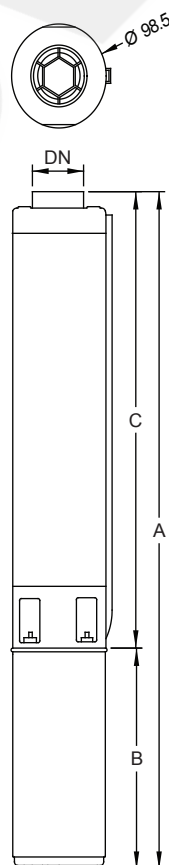

# BOMBA 4" (SERIE BS) - PUMP 4" (BS SERIES)

## CURVAS DE CARACTERÍSTICAS - CHARACTERISTICS CURVES

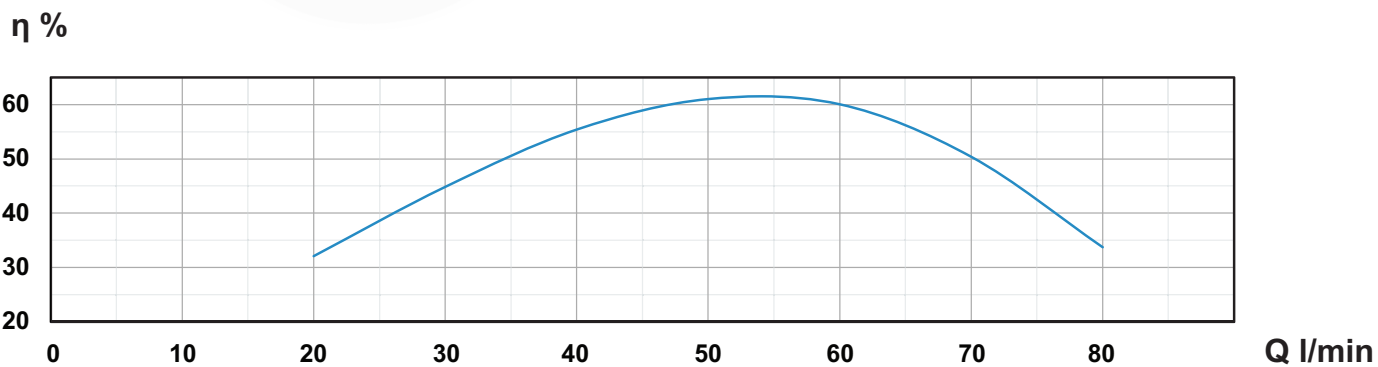
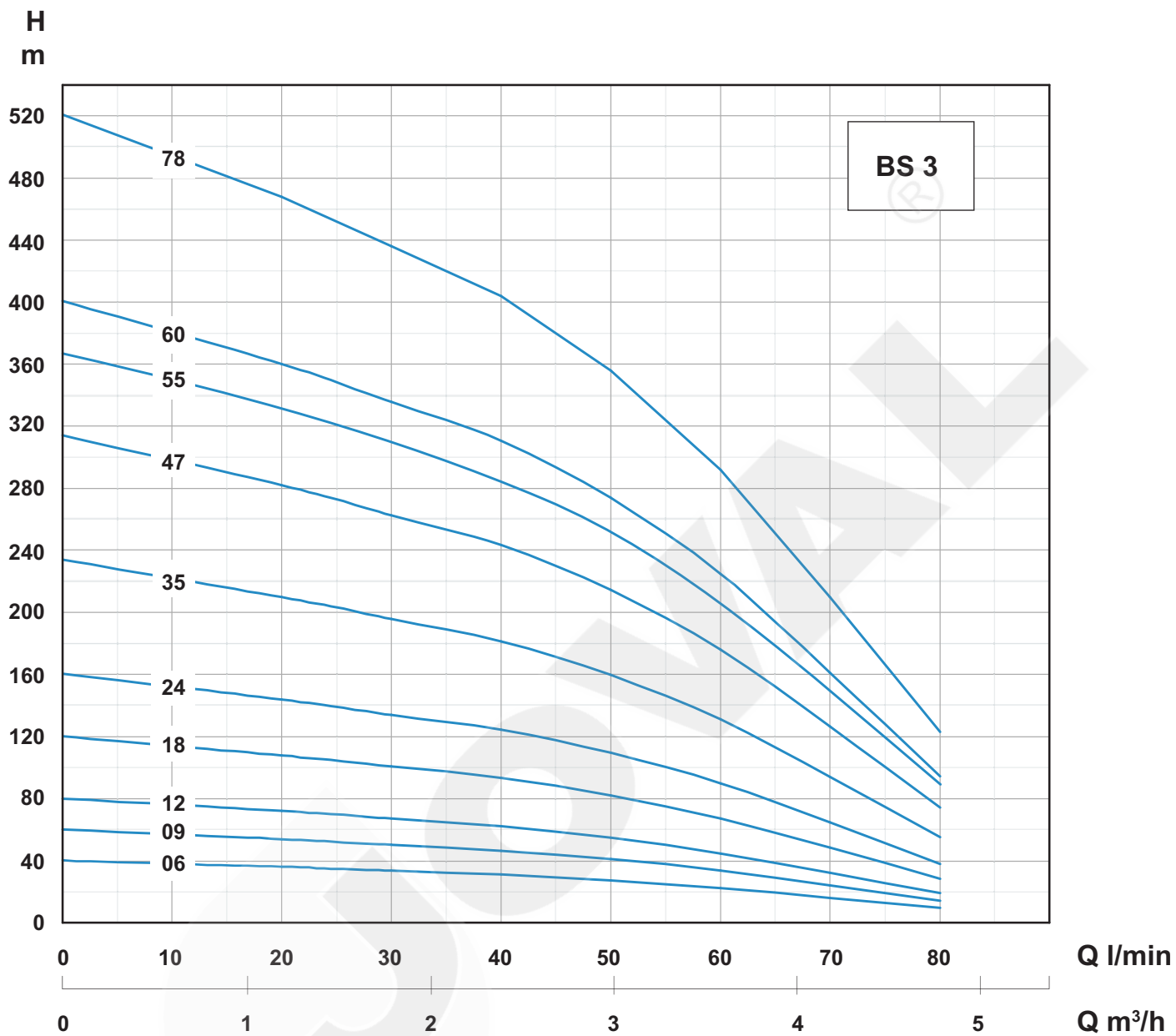

# BOMBA 4" (SERIE BS) - PUMP 4" (BS SERIES)

## CARACTERÍSTICAS - CHARACTERISTICS

Modelo	Motor				Q - Caudal - Flow										
	kW	HP	1~230V	3~400V	m³/h	0	0,6	1,2	1,8	2,4	3	3,6	4,2	4,8	
A			A	l/min	0	10	20	30	40	50	60	70	80		
<b>BS3 06</b>	0,37	0,5	3,3	1,1	H m	40		36	34	31	27	22	16	9	
<b>BS3 09</b>	0,55	0,75	4,3	1,5		60		54	50	47	41	34	24	14	
<b>BS3 12</b>	0,75	1	5,7	2,0		80		72	67	62	55	45	32	19	
<b>BS3 18</b>	1,1	1,5	8,4	2,8		120		108	101	93	82	67	48	28	
<b>BS3 24</b>	1,5	2	10,7	3,9		160		144	134	124	110	90	65	38	
<b>BS3 35</b>	2,2	3	14,7	5,5		234		210	196	181	160	131	94	55	
<b>BS3 47</b>	3	4		7,5		314		282	263	243	215	176	127	74	
<b>BS3 55</b>	3,7	5		9,0		367		330	307	285	251	206	148	87	
<b>BS3 60</b>	4	5,5		9,9		401		360	335	311	274	225	162	95	
<b>BS3 78</b>	5,5	7,5		12,6		521		468	436	404	356	292	210	123	

Q - Caudal  
- Flow

H - Potência nominal do motor  
- Rated motor power output

Modelo	Peso	Altura	Saída
Model	Weight	Height	Salida
	kg	mm	Outlet
<b>BS3 06</b>	3,0	311	1"¼
<b>BS3 09</b>	3,5	377	
<b>BS3 12</b>	4,2	443	
<b>BS3 18</b>	5,6	616	
<b>BS3 24</b>	6,9	748	
<b>BS3 35</b>	9,0	1031	
<b>BS3 47</b>	12,0	1336	
<b>BS3 55</b>	14,5	1531	
<b>BS3 60</b>	16,0	1663	
<b>BS3 78</b>	20,0	2100	

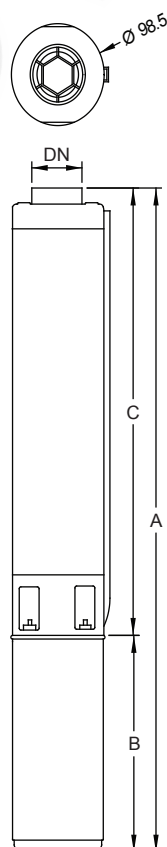

# BOMBA 4" (SERIE BS) - PUMP 4" (BS SERIES)

## CURVAS DE CARACTERÍSTICAS - CHARACTERISTICS CURVES

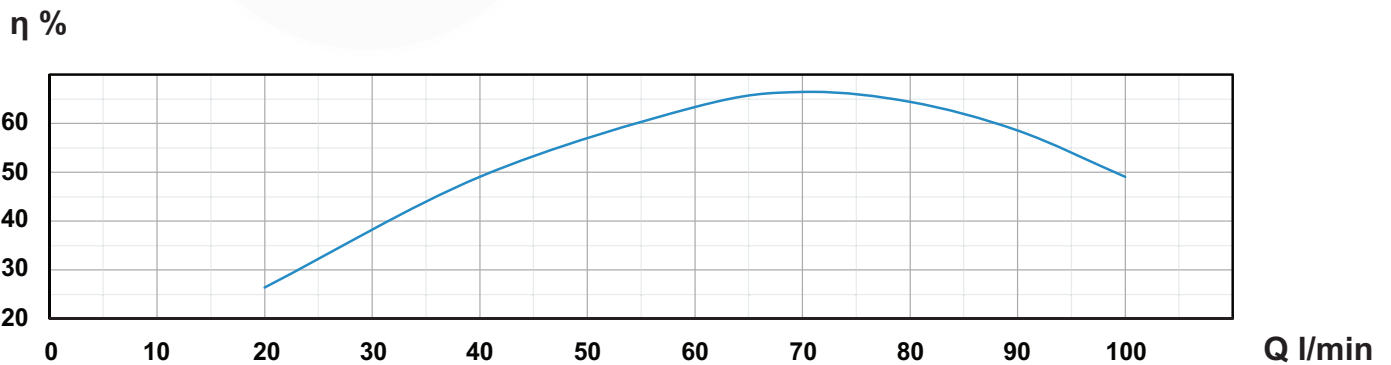
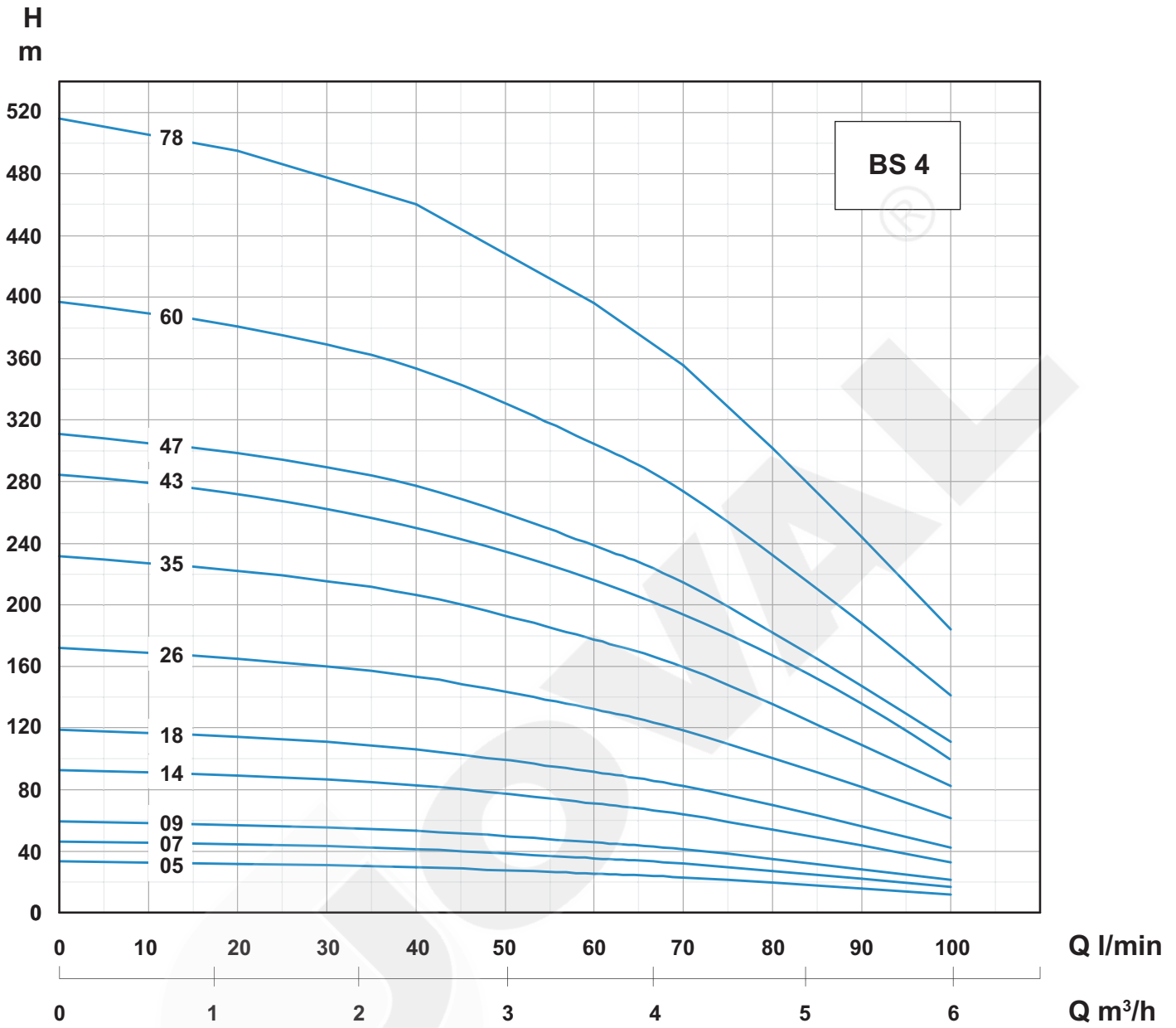

# BOMBA 4" (SERIE BS) - PUMP 4" (BS SERIES)

## CARACTERÍSTICAS - CHARACTERISTICS

Modelo	Motor				m³/h	Q - Caudal - Flow																	
	kW	HP	1~230V A	3~400V A		0	1,2	1,8	2,4	3	3,6	4,2	4,8	5,4	6	7,2	8,4	9,6	10,8	12	15		
Model					l/min	0	20	30	40	50	60	70	80	90	100	120	140	160	180	200	250		
BS4 05	0,37	0,5	3,3	1,1	H m	33	32	31	29	27	25	23	19	16	12								
BS4 07	0,55	0,75	4,3	1,5		46	44	43	41	38	36	32	27	22	17								
BS4 09	0,75	1	5,7	2,0		60	57	55	53	49	46	41	35	28	21								
BS4 14	1,1	1,5	8,4	2,8		93	89	86	83	77	71	64	54	44	33								
BS4 18	1,5	2	10,7	3,9		119	114	110	106	99	91	82	70	56	42								
BS4 26	2,2	3	14,7	5,5		172	165	159	153	143	132	119	101	81	61								
BS4 35	3	4		7,5		232	222	206	206	178	178	160	136	109	82								
BS4 43	3,7	5		9,0		284	273	265	254	239	218	196	166	135	101								
BS4 47	4	5,5		9,9		311	298	287	277	258	239	215	182	147	111								
BS4 60	5,5	7,5		12,6		397	381	367	354	329	305	274	232	147	142								
BS4 78	7,5	10		17,1		516	495	477	460	428	396	356	302	244	184								

Q - Caudal  
- Flow

H - Potência nominal do motor  
- Rated motor power output

Modelo	Peso	Altura	Saída
Model	Weight	Height	Salida
Model	kg	mm	Outlet
BS4 05	2,5	289	1"¼
BS4 07	3,1	333	
BS4 09	3,4	377	
BS4 14	4,4	487	
BS4 18	5,6	616	
BS4 26	7,3	792	
BS4 35	9,6	1035	
BS4 43	11,3	1248	
BS4 47	12,6	1336	
BS4 60	15,5	1663	
BS4 78	19,5	2100	

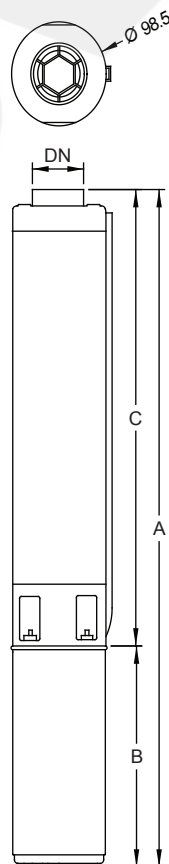

# BOMBA 4" (SERIE BS) - PUMP 4" (BS SERIES)

## CURVAS DE CARACTERÍSTICAS - CHARACTERISTICS CURVES

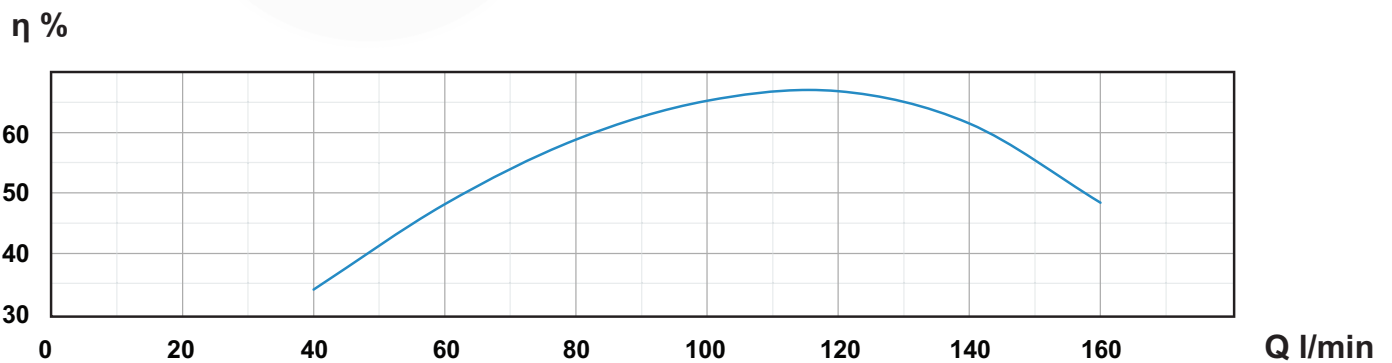
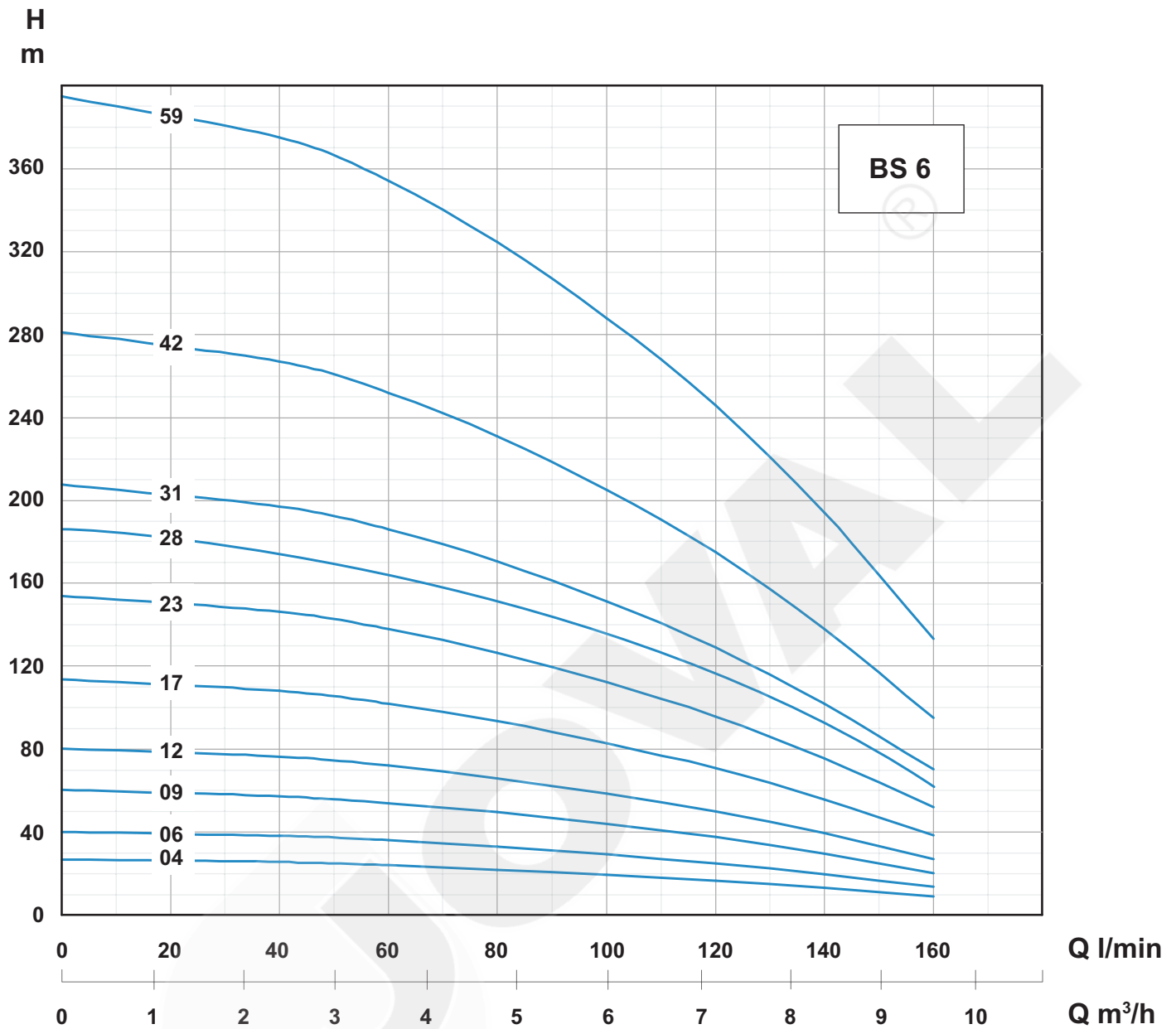

# BOMBA 4" (SERIE BS) - PUMP 4" (BS SERIES)

## CARACTERÍSTICAS - CHARACTERISTICS

Modelo	Motor				Q - Caudal - Flow																
	kW	HP	1~230V	3~400V	m <sup>3</sup> /h	0	1,2	1,8	2,4	3	3,6	4,2	4,8	5,4	6	7,2	8,4	9,6	10,8	12	15
A			A	l/min	0	20	30	40	50	60	70	80	90	100	120	140	160	180	200	250	
BS6 04	0,55	0,75	4,3	1,5	H m	27			25	25	24	23	22	21	20	17	13	9			
BS6 06	0,75	1	5,7	2,0		40			38	37	36	35	33	31	29	25	20	14			
BS6 09	1,1	1,5	8,4	2,8		60			57	56	54	52	50	47	44	38	30	20			
BS6 12	1,5	2	10,7	3,9		80			76	74	72	69	66	62	59	50	39	27			
BS6 17	2,2	3	14,7	5,5		114			108	105	102	98	94	88	83	71	56	38			
BS6 23	3	4		7,5		154			146	142	138	133	127	119	112	96	76	52			
BS6 28	3,7	5		9,0		187			178	173	168	161	154	145	137	117	92	63			
BS6 31	4	5,5		9,9		207			197	192	186	179	171	161	151	129	102	70			
BS6 42	5,5	7,5		12,6		281			267	260	252	242	231	218	205	175	138	95			
BS6 59	7,5	10		17,1		395			375	365	354	340	325	306	288	246	194	133			

Q - Caudal  
- Flow

H - Potência nominal do motor  
- Rated motor power output

Modelo	Peso	Altura	Saída
Model	Weight	Height	Salida
Model	kg	mm	Outlet
BS6 04	2,6	299	2"
BS6 06	3,1	359	
BS6 09	3,9	449	
BS6 12	5,0	580	
BS6 17	6,4	730	
BS6 23	8,3	951	
BS6 28	9,8	1142	
BS6 31	10,8	1232	
BS6 42	14,2	1603	
BS6 59	19,7	2154	

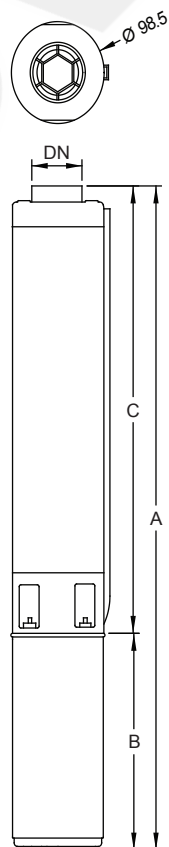

# BOMBA 4" (SERIE BS) - PUMP 4" (BS SERIES)

## CURVAS DE CARACTERÍSTICAS - CHARACTERISTICS CURVES

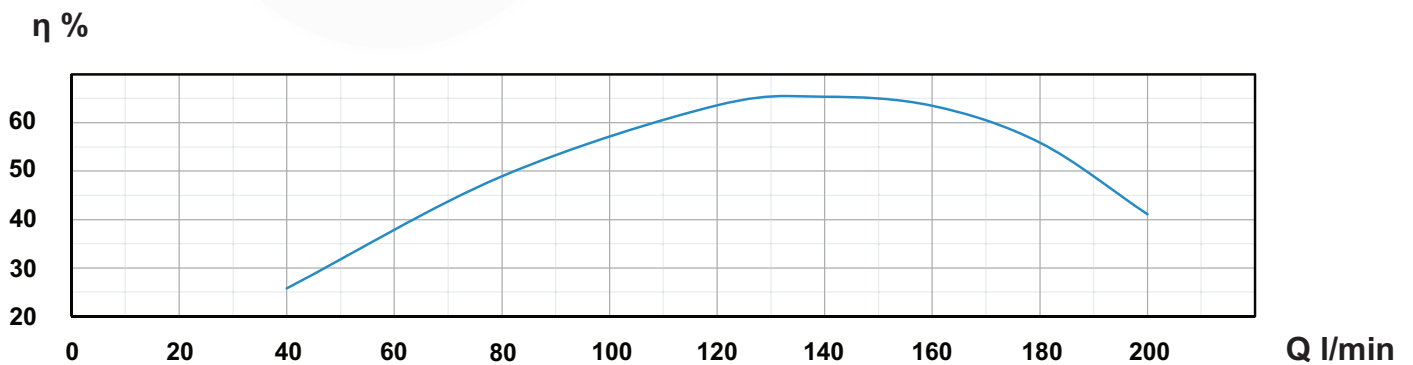
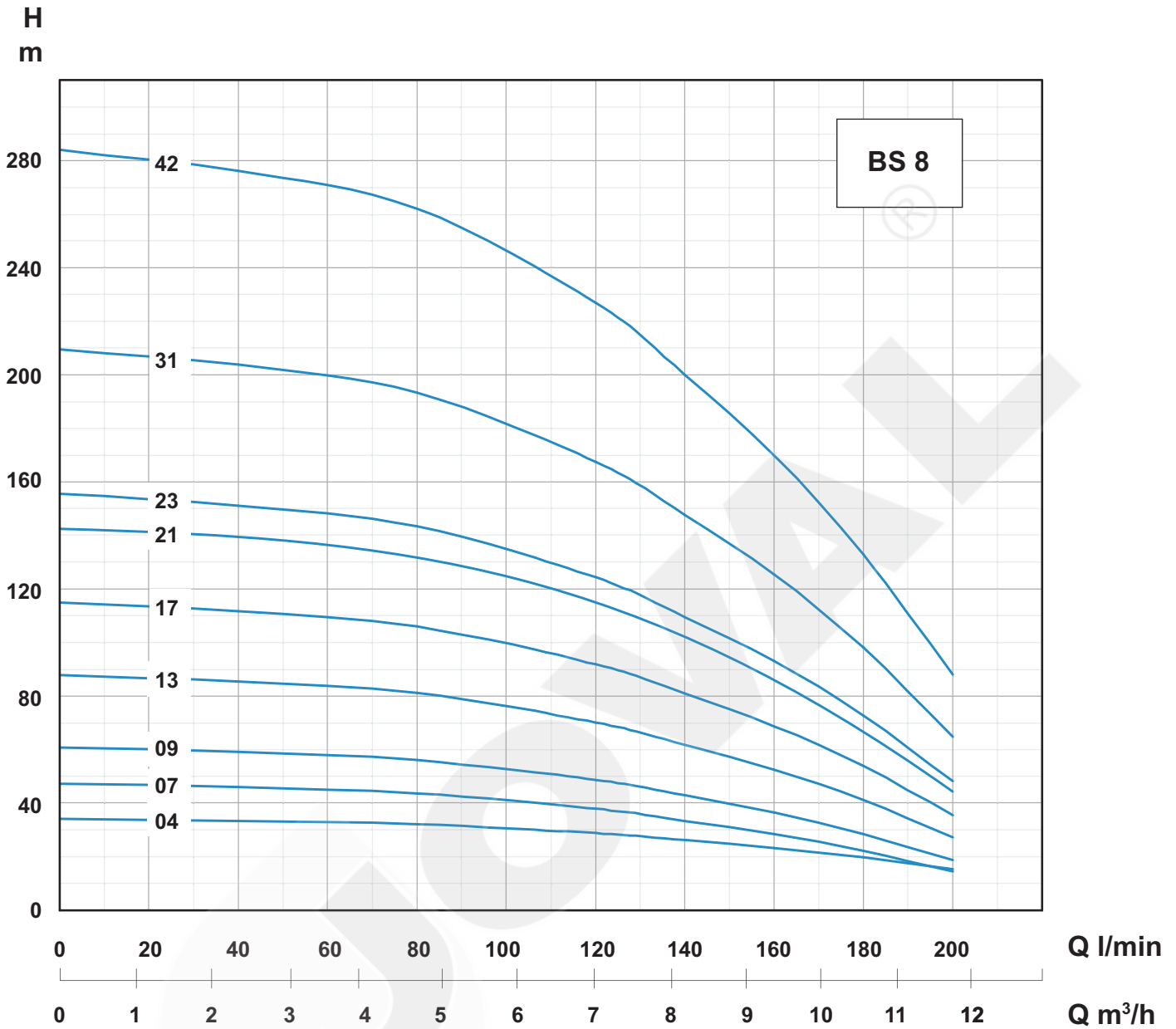

# BOMBA 4" (SERIE BS) - PUMP 4" (BS SERIES)

## CARACTERÍSTICAS - CHARACTERISTICS

Modelo	Motor				m³/h	Q - Caudal - Flow																
	kW	HP	1~230V A	3~400V A		0	1,2	1,8	2,4	3	3,6	4,2	4,8	5,4	6	7,2	8,4	9,6	10,8	12	15	
Model					l/min	0	20	30	40	50	60	70	80	90	100	120	140	160	180	200	250	
<b>BS8 04</b>	0,75	1	5,7	2,0	H m	27				26	26	25	25	24	23	22	19	16	13	8		
<b>BS8 07</b>	1,1	1,5	8,4	2,8		47					46	45	45	44	43	41	38	33	28	22	15	
<b>BS8 09</b>	1,5	2	10,7	3,9		61					59	58	57	56	55	53	49	43	36	29	19	
<b>BS8 13</b>	2,2	3	14,7	5,5		88					85	84	83	81	79	76	70	62	53	41	27	
<b>BS8 17</b>	3	4		7,5		115					111	110	108	106	103	100	92	81	69	54	36	
<b>BS8 21</b>	3,7	5		9,0		142					137	135	133	131	128	123	114	100	85	67	44	
<b>BS8 23</b>	4	5,5		9,9		156					150	148	146	143	140	135	124	110	93	73	48	
<b>BS8 31</b>	5,5	7,5		12,6		210					202	200	197	193	188	182	168	148	125	98	65	
<b>BS8 42</b>	7,5	10		17,1		284					273	271	268	262	255	247	227	200	170	133	88	

Q - Caudal  
- Flow

H - Potência nominal do motor  
- Rated motor power output

Modelo	Peso	Altura	Saída
Model	Weight	Height	Salida
	kg	mm	Outlet
<b>BS8 04</b>	2,8	299	2"
<b>BS8 07</b>	3,3	389	
<b>BS8 09</b>	3,9	449	
<b>BS8 13</b>	4,3	610	
<b>BS8 17</b>	6,3	730	
<b>BS8 21</b>	7,5	891	
<b>BS8 23</b>	8,2	951	
<b>BS8 31</b>	10,7	1232	
<b>BS8 42</b>	14,2	1603	

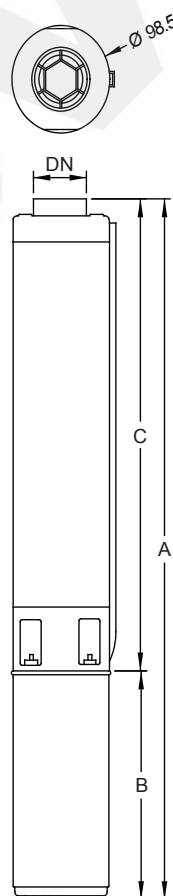

# BOMBA 4" (SERIE BS) - PUMP 4" (BS SERIES)

## CURVAS DE CARACTERÍSTICAS - CHARACTERISTICS CURVES

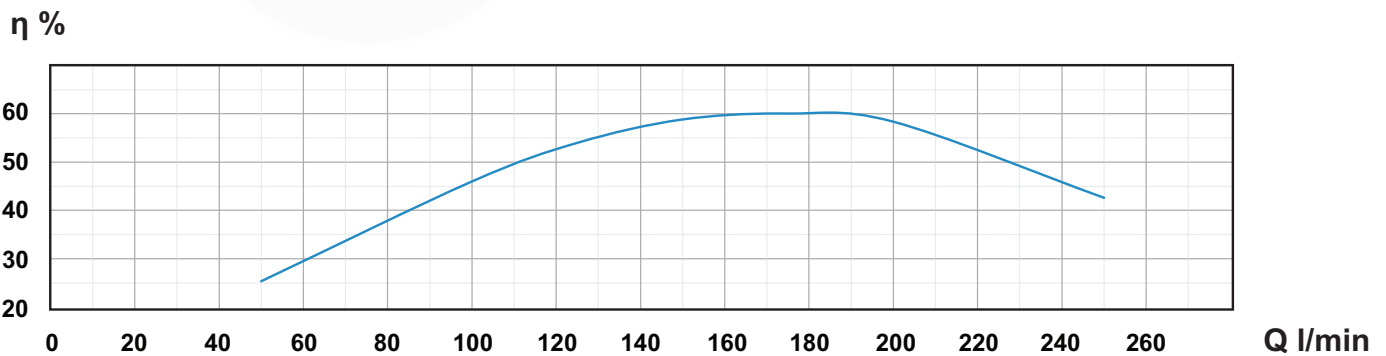
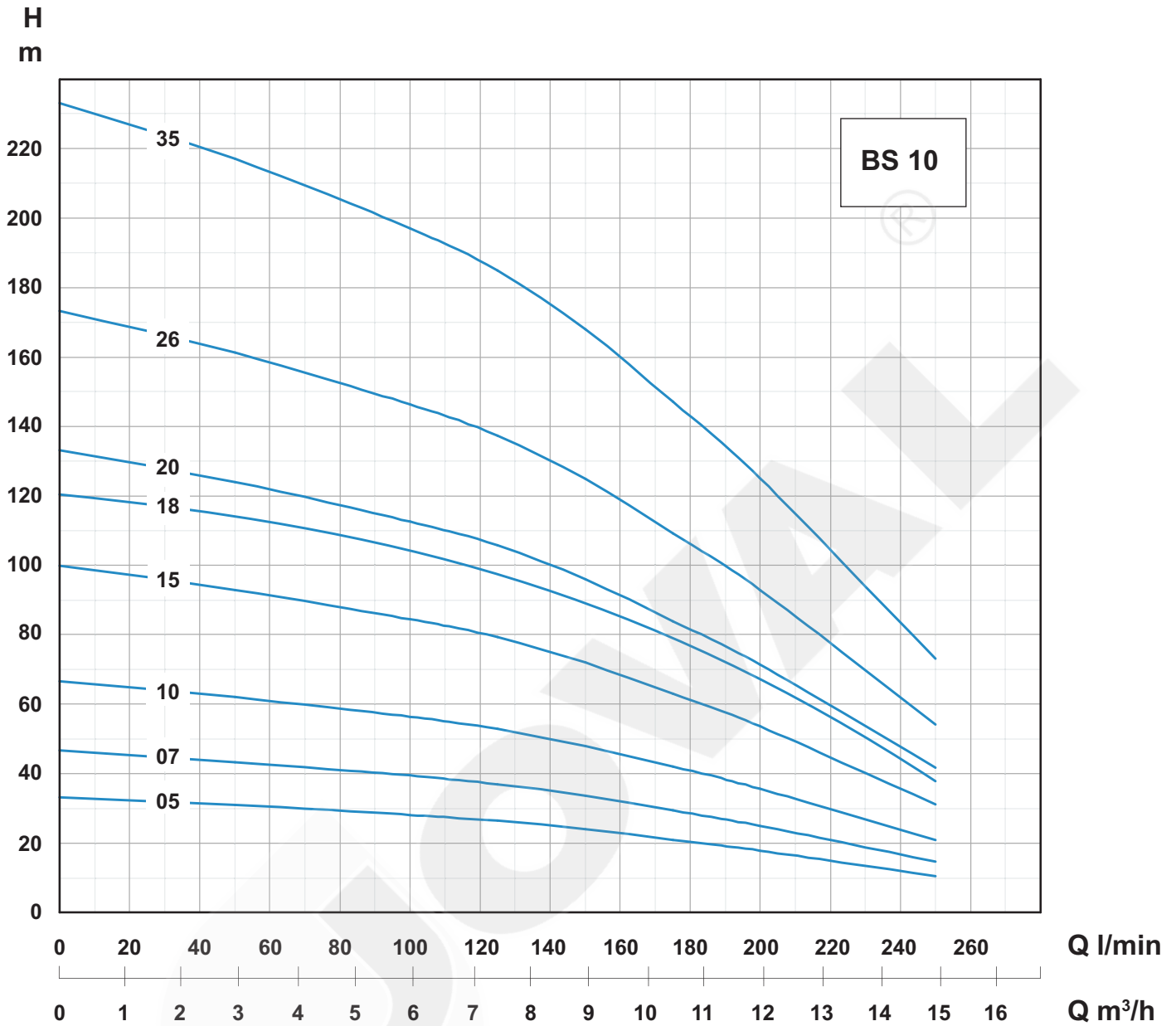

# BOMBA 4" (SERIE BS) - PUMP 4" (BS SERIES)

## CARACTERÍSTICAS - CHARACTERISTICS

Modelo	Motor				Q - Caudal - Flow																
	Model	kW	HP	1~230V	3~400V	m³/h	0	1,2	1,8	2,4	3	3,6	4,2	4,8	5,4	6	7,2	8,4	9,6	10,8	12
A				A	l/min	0	20	30	40	50	60	70	80	90	100	120	140	160	180	200	250
BS10 05	1,1	1,5	8,4	2,8	H m	33					30	30	29	29	28	27	25	23	20	18	10
BS10 07	1,5	2	10,7	3,9		47					43	42	41	40	39	38	35	32	29	25	15
BS10 10	2,2	3	14,7	5,5		67					61	60	59	57	56	54	50	46	41	36	21
BS10 15	3	4		7,5		100					91	90	88	86	84	81	75	69	61	54	31
BS10 18	3,7	5		9,0		120					110	108	106	103	101	98	90	82	74	64	38
BS10 20	4	5,5		9,9		133					122	119	117	115	113	107	100	91	82	71	42
BS10 26	5,5	7,5		12,6		173					158	155	152	149	146	140	130	119	106	93	54
BS10 35	7,5	10		17,1		233					213	209	205	201	197	188	130	160	143	125	73

Q - Caudal - Flow      H - Potência nominal do motor  
- Rated motor power output

Modelo	Peso	Altura	Saída
Model	Weight	Height	Salida
Model	kg	mm	Outlet
BS10 05	3,7	439	2"
BS10 07	4,4	543	
BS10 10	6,0	740	
BS10 15	8,5	1041	
BS10 18	10,0	1238	
BS10 20	11,0	1342	
BS10 26	13,8	1695	
BS10 35	18,0	2204	

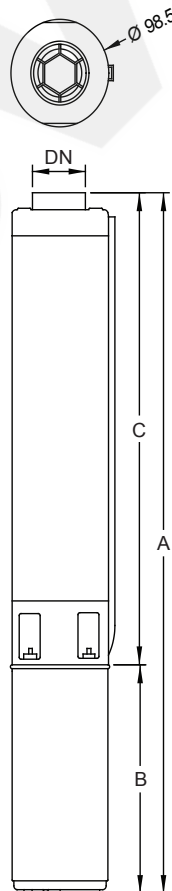

# BOMBA 4" (SERIE BS) - PUMP 4" (BS SERIES)

## CURVAS DE CARACTERÍSTICAS - CHARACTERISTICS CURVES

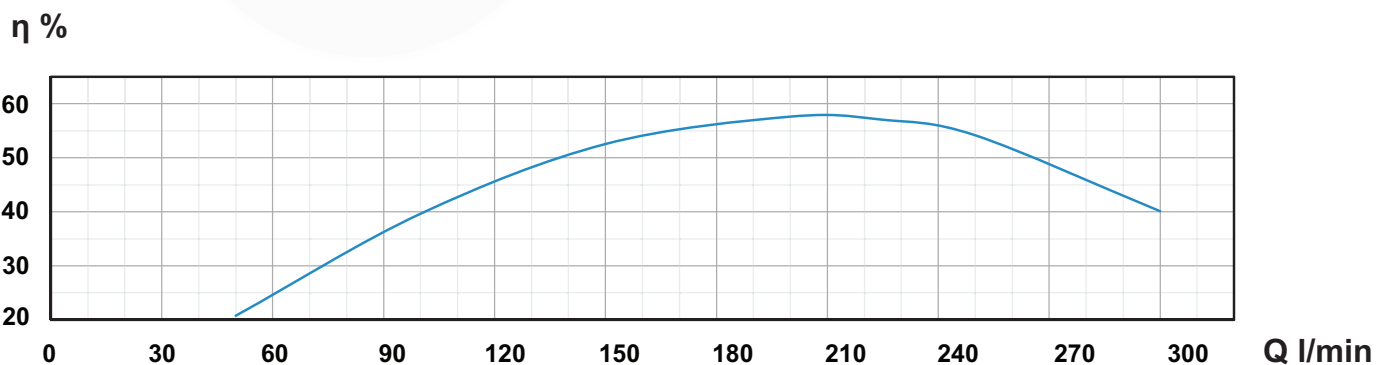
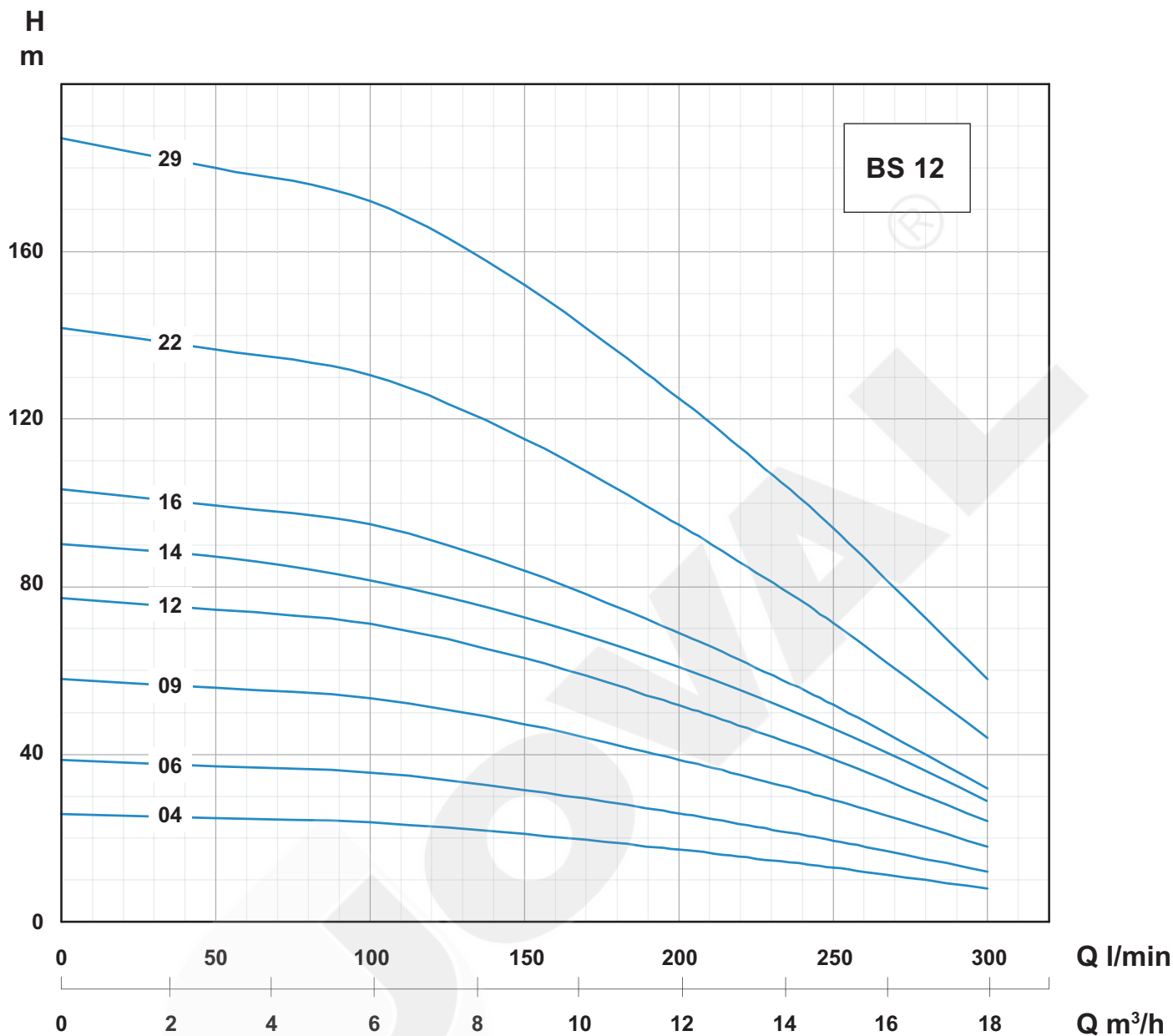

# BOMBA 4" (SERIE BS) - PUMP 4" (BS SERIES)

## CARACTERÍSTICAS - CHARACTERISTICS

Modelo	Motor				Q - Caudal - Flow												
	kW	HP	1~230V	3~400V	m³/h	0	4,8	5,4	6	7,2	8,4	9,6	10,8	12	15	18	21,6
A			A	l/min	0	80	90	100	120	140	160	180	200	250	300	360	
<b>BS12 04</b>	1,1	1,5	8,4	2,8	H m	26	24	24	23	23	22	20	19	17	13	8	
<b>BS12 06</b>	1,5	2	10,7	3,9		39	36	36	35	34	32	30	28	26	19	12	
<b>BS12 09</b>	2,2	3	14,7	5,5		58	54	53	53	51	48	46	42	39	29	18	
<b>BS12 12</b>	3	4		7,5		77	72	71	70	68	65	61	56	52	39	24	
<b>BS12 14</b>	3,7	5		9,0		90	86	84	83	80	77	72	67	60	45	28	
<b>BS12 16</b>	4	5,5		9,9		103	96	95	94	90	86	81	75	69	52	32	
<b>BS12 22</b>	5,5	7,5		12,6		142	132	130	129	124	118	112	103	95	71	44	
<b>BS12 29</b>	7,5	10		17,1		187	174	172	170	164	156	147	136	125	94	58	

Q - Caudal - Flow      H - Potência nominal do motor - Rated motor power output

Modelo	Peso	Altura	Saída
Model	Weight	Height	Salida
Model	kg	mm	Outlet
<b>BS12 04</b>	3,5	387	2"
<b>BS12 06</b>	4,2	491	
<b>BS12 09</b>	5,7	688	
<b>BS12 12</b>	7,0	885	
<b>BS12 14</b>	8,0	989	
<b>BS12 16</b>	9,0	1134	
<b>BS12 22</b>	12,0	1487	
<b>BS12 29</b>	16,0	1892	

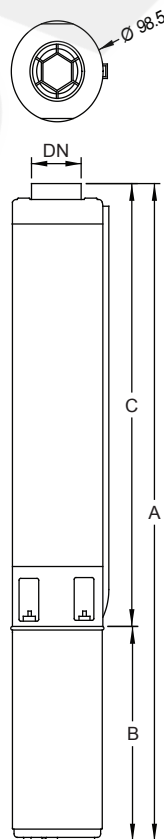

# BOMBA 4" (SERIE BS) - PUMP 4" (BS SERIES)

## CURVAS DE CARACTERÍSTICAS - CHARACTERISTICS CURVES

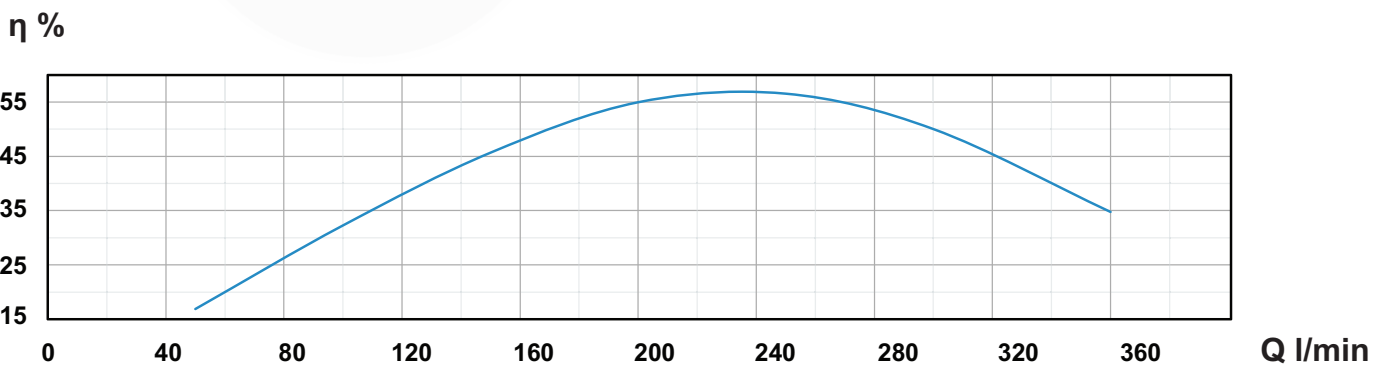
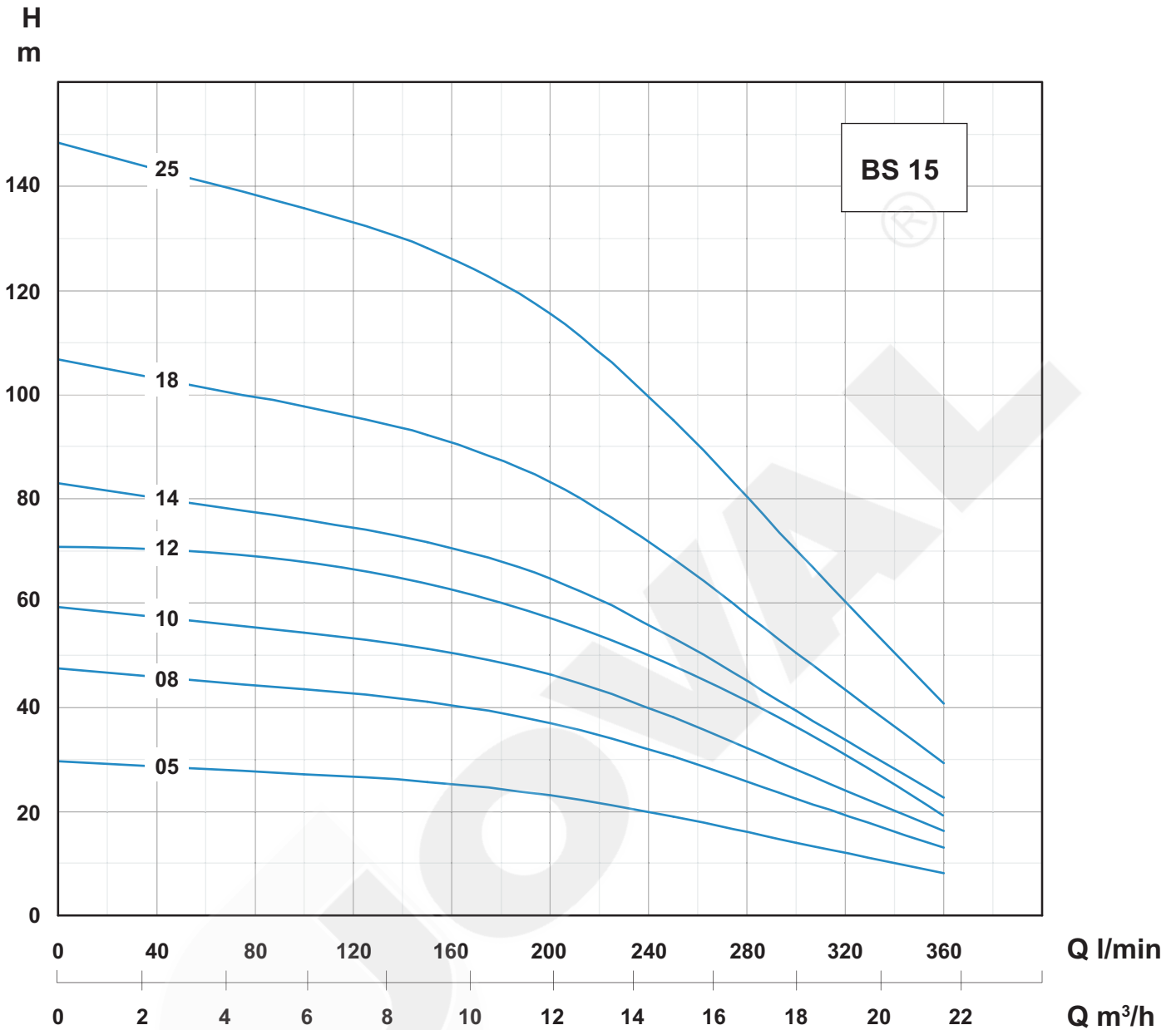

# BOMBA 4" (SERIE BS) - PUMP 4" (BS SERIES)

## CARACTERÍSTICAS - CHARACTERISTICS

Modelo	Motor				Q - Caudal - Flow												
	kW	HP	1~230V	3~400V	m³/h	0	4,8	5,4	6	7,2	8,4	9,6	10,8	12	15	18	21,6
A			A	l/min	0	80	90	100	120	140	160	180	200	250	300	360	
<b>BS15 05</b>	1,5	2	10,7	3,9	H m	30			30	27	26	25	24	23	23	14	8
<b>BS15 08</b>	2,2	3	14,7	5,5		47			43	43	42	40	39	37	30	22	13
<b>BS15 10</b>	3	4		7,5		59			54	54	53	50	49	46	38	28	16
<b>BS15 12</b>	3,7	5		9,0		71			65	64	62	60	58	56	46	34	20
<b>BS15 14</b>	4	5,5		9,9		83			76	75	74	70	68	65	53	39	23
<b>BS15 18</b>	5,5	7,5		12,6		107			98	97	95	90	88	83	69	51	29
<b>BS15 25</b>	7,5	10		17,1		148			136	134	131	125	122	116	95	70	41

Q - Caudal  
- Flow

H - Potência nominal do motor  
- Rated motor power output

Modelo	Peso	Altura	Saída
Model	Weight	Height	Salida
Model	kg	mm	Outlet
<b>BS15 05</b>	3,8	439	2"
<b>BS15 08</b>	5,0	595	
<b>BS15 10</b>	6,1	740	
<b>BS15 12</b>	7,0	885	
<b>BS15 14</b>	8,0	989	
<b>BS15 18</b>	10,2	1238	
<b>BS15 25</b>	13,5	1643	

